

Novatek roll plants are available with belt widths of 600mm, 800mm and 1000mm and utilise the latest technology to produce a wide range of bakery goods.

Modular design ensures that Novatek roll plants can be configured to meet the individual requirements of our customers.

Make up features include flour dusting, pinning, sheeting, coiling and long moulding (with or without channel boards).

Intermediate provers, wetter seeders, cross sheeters and indexing cross conveyors can be included to suit production needs.

Reciprocating panners are offered with a stroke of up to 1metre and can be supplied with an electro-mechanical batching system.

THE RANGE OF 428 DIVIDER ROUNDERS OFFERS:

- 4, 5, 6 or 8 row configuration.
- Standard inbuilt bulk dough conveyor (70kg)
- Bulk feed hopper with capacity up to 250kg is optional.
- Rounded products are discharged on standard conveyor or optional spreading bands.
- Weight range of 10g-200g (with change parts) across all rows simultaneously (except 8 row).
- Weights from 200g-500g with lane reduction and change parts.
- Maximum stroking rate of 50 spm.
- Low noise level >76dB(A).
- Stainless steel covers are standard.
- No dividing oil.



OUTPUT/WEIGHT RANGE

NOVATEK MODEL	WEIGHT RANGE ALL ROWS	MAX HOURLY OUTPUT
428-4 row	10-200g	12000 pph
428-5 row	10-200g	15000 pph
428-6 row	10-200g	18000 pph
428-8 row	10-125g	24000 pph

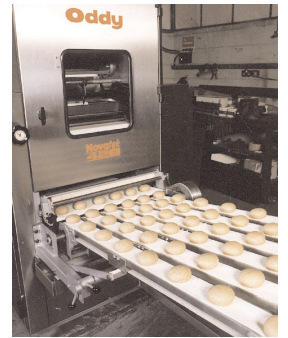
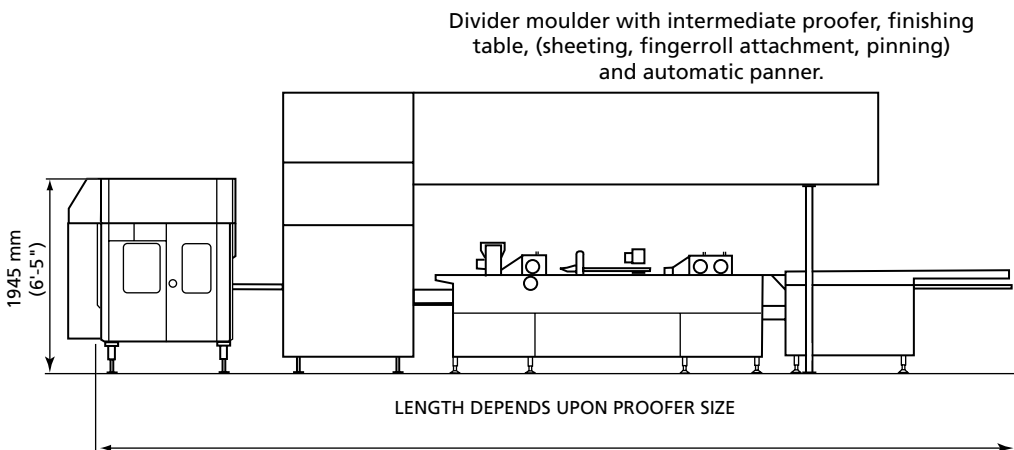
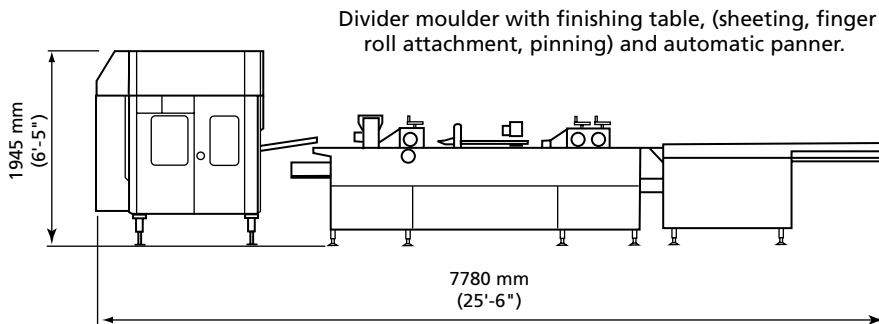
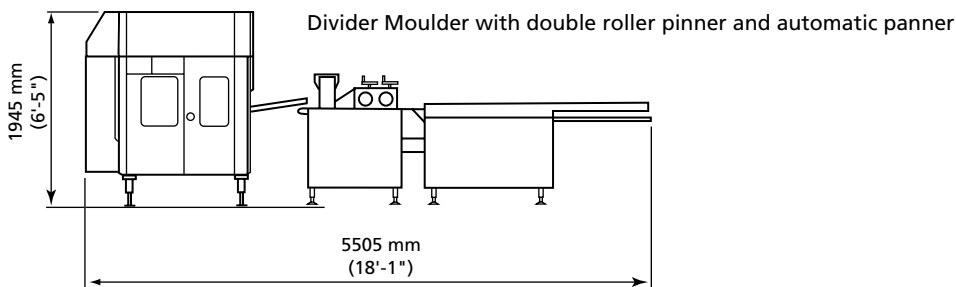
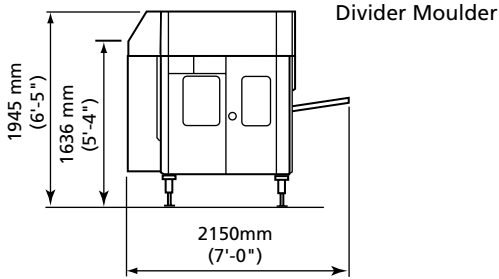

Due to continuous technical developments, specifications may be modified without notice.

