



könig
MASCHINEN



Rex Automat Plants

for round, long rolled, folded, convoluted and flattened dough pieces, seeded or unseeded

Hourly capacity: up to 9000 pieces



*Rex Automat Classic and Futura
The heart of every roll plant*

KÖNIG Maschinen - Quality that lasts



The head of every roll plant...



Rex Automat Classic: e.g. T4 S-MKB/1-SK58

Rex Automat Classic

- 4-, 5- or 6-pocket execution
- hourly capacity up to 6000, 7500 or 9000 pieces respectively
- row reduction possible
- typical weight ranges, depending on dough:
 - 22 - 55 g
 - 35 - 85 g
 - 55 - 125 g
- special weight ranges available on request
- disconnectable rounding action
- adjustable rounding pressure
- with enlarged dough hopper on request



Rex Automat Futura: e.g. T4 S - MKB/1-SK58 + 2-SK67

Rex Automat Futura

Based on the same well proven gentle dough handling principle, the Rex Automat Futura is distinguished by the following additional features:

- considerable extension of the weight range by using the double chamber principle
- typical weight ranges depending on dough:
 - 22 - 85 g
 - 35 - 120 g
- special weight ranges and combinations with specially shaped pistons (e.g. for American Cookies) are available on request

Possibility to fit additional so-called "RUSTIKA" pistons for the production of angular, rustic rolls

Examples of RUSTIKA-angular rustic rolls





Rex Automat Plants - examples of possible executions

All versions of our Rex Automat Plants can either be equipped with the Rex Automat Classic or the Rex Automat Futura as the head machine.

The variable modular construction - Rex Automat, tripl resting belt or resting chamber, forming station, seeder and setting device - in different executions - enables us to build up complete plants corresponding to the individual demands of our customers.

The individual components are:

Dough hopper

Rex Automat Classic or Futura

Triple resting belt or resting chamber



Forming station

Seeder

Setting device



Plants with step by step type setting devices

T 4 S-MKB-Z-AK600/Pt

4pocket, with intermediate belt Z and setting device AK600- nominal width 600 mm, setting on to tilting setters Pt.

The basic plant for the efficient production of round stamped rolls in combination with our well proven REGINA - roll stamping machine
Capacity: up to 6000 pieces per hour

T 5 S-MKB-Z-AL660/Bl

5pocket, with intermediate belt Z and setting device AL660- nominal width 660 mm, setting on to baking trays Bl.

Products: round
Capacity: up to 7500 pieces per hour

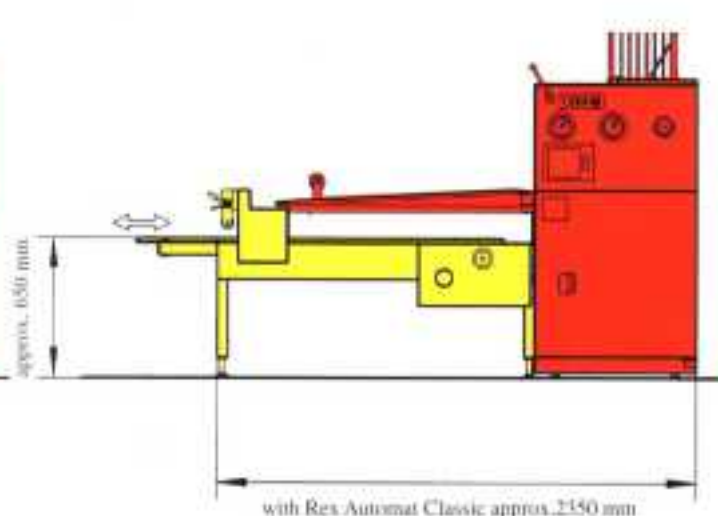
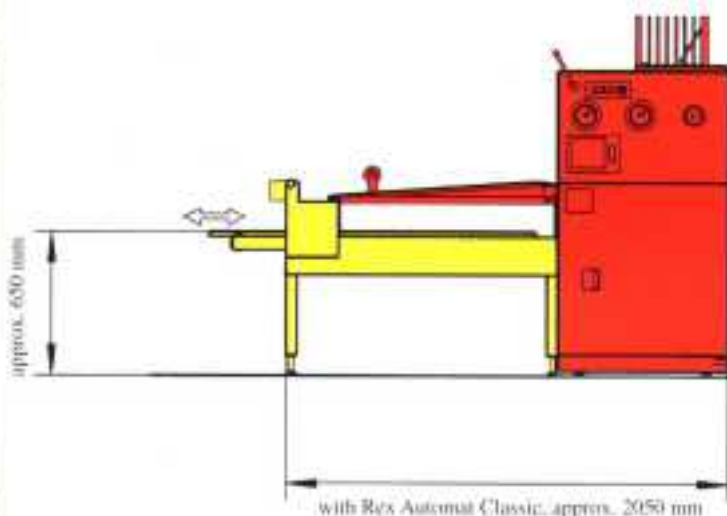



König

MASCHINEN



T 5/4 S-MKB-R-AL660/BI

5-pocket with row reduction to 4-pocket operation, built in long rolling pressure board R and setting device AL660- nominal width 660 mm, setting on to baking trays BI.

Products: round, long rolled

Capacity: 5 pocket: up to 7500 pieces per hour

4 pocket: up to 6000 pieces per hour

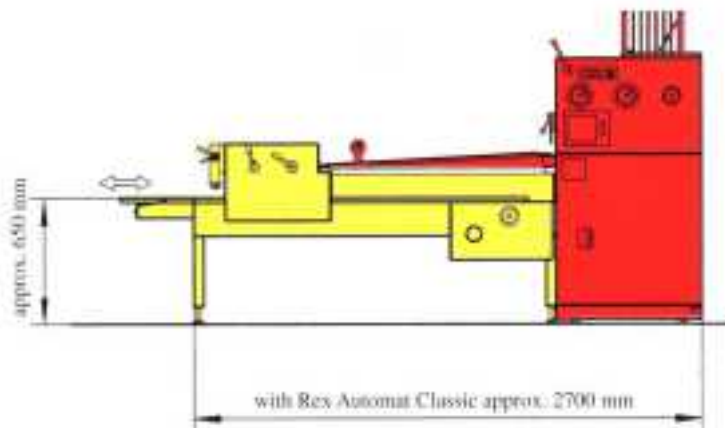

T 6/5/4 SBBIII-MKB-SCHR-DB610-KB95/21 rows

6-pocket with row reduction to 5- or 4-pocket operation, triple resting belt SBBIII for approx. 3 minutes resting time and forming station SCHR-DB- nominal width 610 mm. Setting by means of chain belt KB95/21 on to oven-length tilting setters or baking trays.

Products: round, long rolled, long rolled and folded

Capacity: 6 pocket: up to 9000 pieces per hour

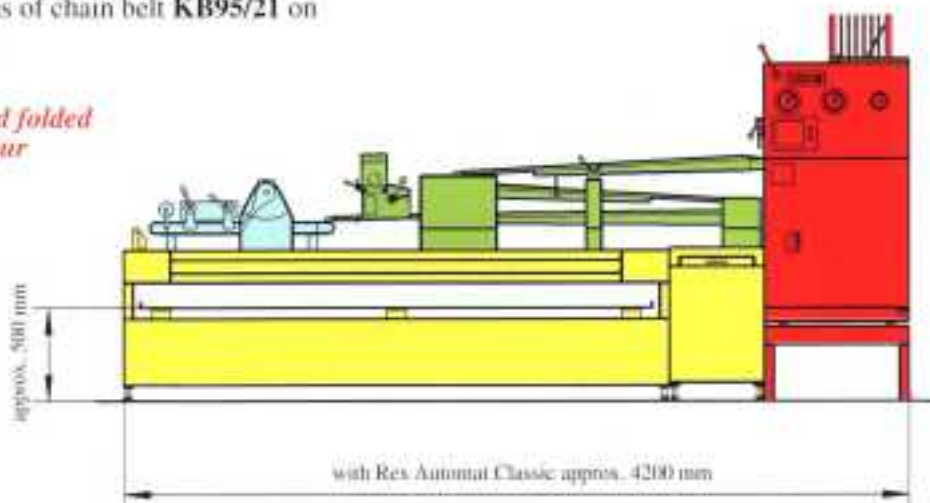

T 5/4/3 SBBIII-MKB-SCHR-RR610-MO(WB)610-AK660/BI

5-pocket with row reduction to 4- or 3-pocket operation, triple resting belt SBBIII for approx. 3 minutes resting time, forming station SCHR-RR and waterbath seeder MO(WB)- each with nominal width 610 mm, as well as setting device AK660- nominal width 660 mm. Setting on to baking trays BI.

Products: round, long rolled, long rolled and folded, flattened, seeded

Capacity: up to 7500, 6000 or 4500 pieces per hour at 5-, 4- or 3-pocket operation respectively

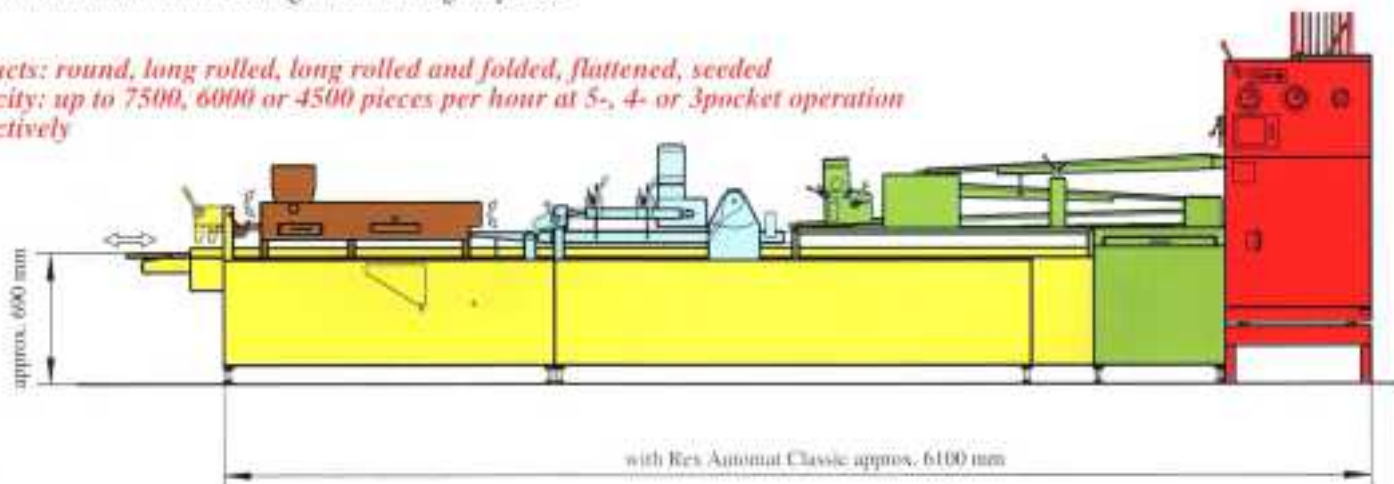



T 6/4 SBBIII-MKB-SCHR-RR610-AK660-BZ

6pocket with row reduction to 4pocket operation, large dough hopper TRÖ 160, triple resting belt SBBIII for approx. 3 minutes resting time, forming station SCHR-RR- nominal width 610 mm, setting device AK660- nominal width 660 mm - and automatic tray feeding BZ.
Setting on to baking trays.

Products: round, long rolled, long rolled and folded, flattened
Capacity: up to 9000 or 6000 pieces per hour at 6- or 4pocket operation respectively

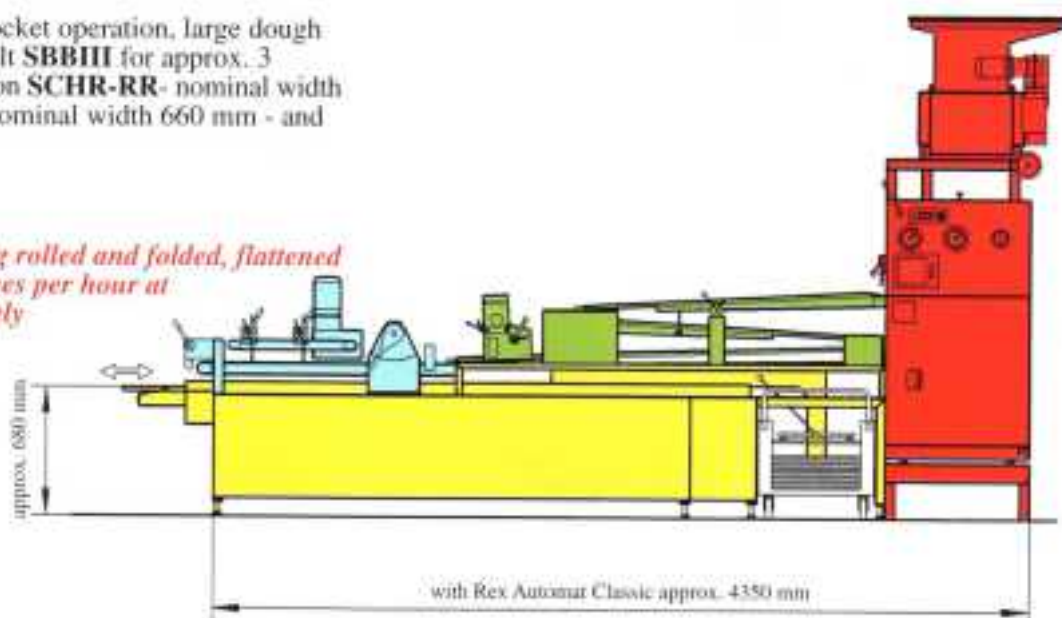

Plants with manual discharge of the dough pieces

T 4 SV-MKB-SCHR-DBH/Supermarket

4pocket, with forming station consisting of pre-pressure roller SCHR and liftable pressure board DBH- nominal width 610 mm - as well as collecting tray for the manual discharge of the products.

Products: round, long rolled, long rolled and folded
Capacity: up to 6000 pieces per hour

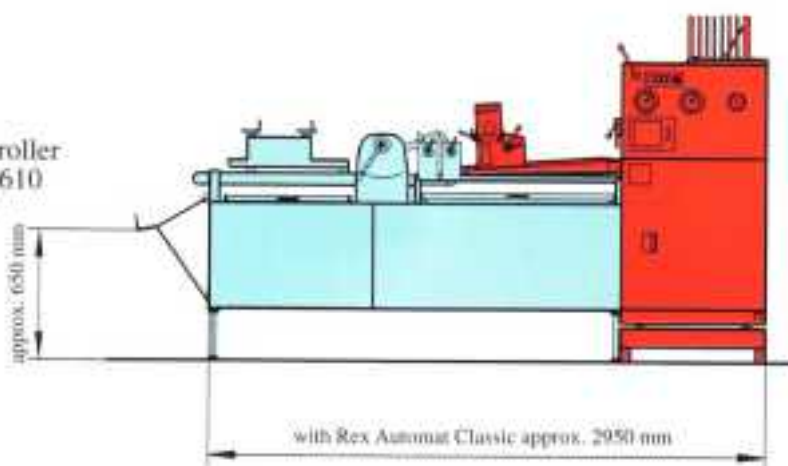

T 4 SV-MKB-RR/Superstore

4pocket, with forming station consisting of bottom belt and driven top belt RR- nominal width 610 mm - as well as collecting tray for the manual discharge of the products.

Products: round, long rolled, flattened
Capacity: up to 6000 pieces per hour

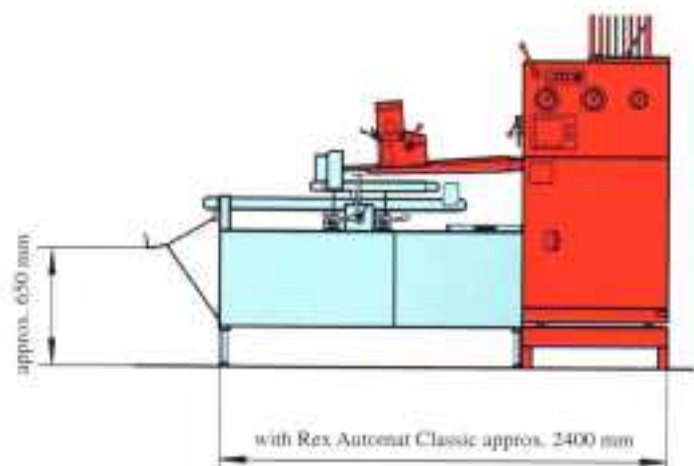



T 5/4/3S-MKB-EK600-WDK-DB610-MO(WB)610-ABI660(800)

5-pocket with row reduction to 4- or 3-pocket operation, resting chamber EK600 for a proofing time of approx. 3 minutes, forming station WDK-DB and waterbath seeder MO(WB)- each with working width 610 mm, as well as retracting belt type Industry ABI- nominal width 660 mm/max. retracting length 800 mm. Setting on to baking trays or carriers.

*Products: round, long rolled, convoluted, seeded
Capacity: up to 7500, 6000 or 4500 pieces per hour
at 5-, 4- or 3-pocket operation respectively*

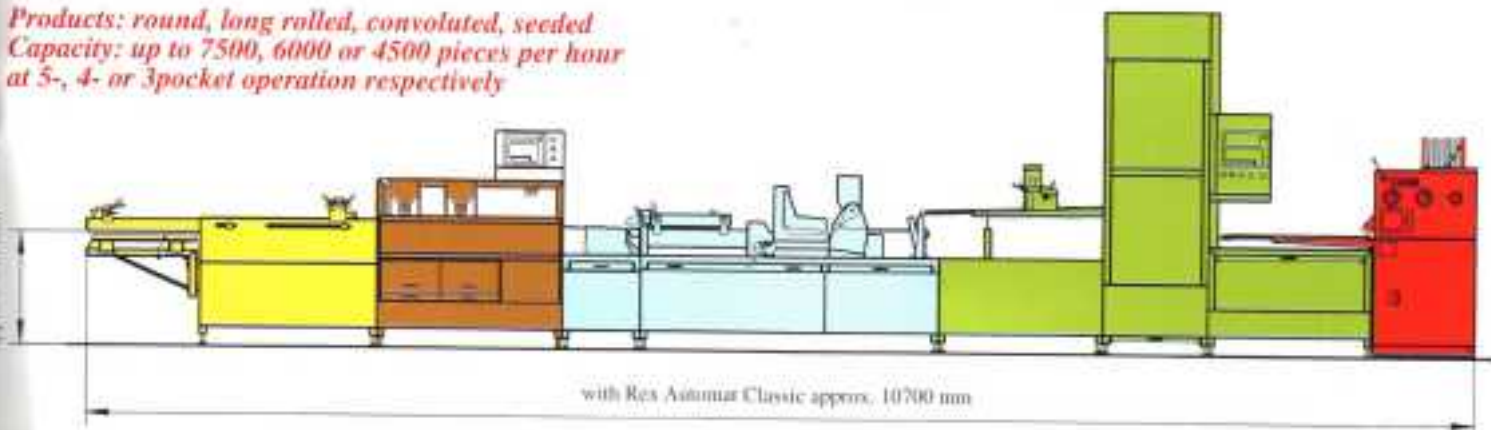

The components in detail

Triple resting belt system SBBIII

- for a resting time of approx. 3 minutes at 25 strokes/minute
- nominal widths: 600 or 800 mm

first belt: spreading finger belt with continuously adjustable cross separation (for machines with row reduction), nominal length 1600 mm

second belt: continuous, nominal length 1600 mm

third belt: continuous, nominal length 2300 mm

Resting chamber EK600

- resting chamber with e.g. 80, 100 or 120 swings for a resting time of approx. 3, 4 or 5 minutes respectively
- nominal width: 600 mm, -alternatively 800 mm, if requested
- sterilization of the empty swings by means of UV cold-cathode tubes



triple resting belt system, SBBIII for approx. 3 minutes resting time



resting chamber EK600



Step by step type setting devices

Type	Working principle	Carriers	available with	
			nom. width (mm)	max. setting length (mm)
AK/Pl	fixed forward step	tilting setters	600	780
AL/Pl	by means of forward catch	tilting setters	600	980
KB95/21	chain belt with tiltable swings fixed step 95 mm	tilting setters baking trays	600	Number of swings to be tilted simultaneously adjustable up to max. of 21
AK/BI	4 different steps	baking trays	600/660	800
AL/BI	adjustable via MKB control	baking trays	600/660	1000



AK 600/Pl



AL 600/BI

Freely adjustable retracting belts

Type	Working principle	Carriers	available with	
			nom. width (mm)	max. retracting length (mm)
ABs	Retracting table: Step and retracting length as well as height, width and length for the baking sheets are infinitely adjustable. -usable up to max. 25 strokes/min.	e.g. baking trays, tipping setters	610/800	800/1000
ABe	Chain retracting belt: Step and retracting length infinitely adjustable. Operable from one side only. Setting of hatched products is possible. -usable up to max. 50 strokes/min.	e.g. baking trays, tipping setters	610/800	1000*
ABI	Retracting belt in industrial execution: Step and retracting length as well as height, width and length for the baking sheets are infinitely adjustable. Operable from three sides. Connection of cross-conveyors possible. Possibility to set batches products. For highest capacities of 50 strokes/min.	e.g. baking trays, tipping setters	660/800/1000/1300	800/1000*

*Further retracting lengths on request



ABe 800/1000



ABI 800/1000



Forming station SCHR-...

Consisting of:

- height adjustable pre-pressure roller-SCHR
- fitted folding claws or drag belts
- bottom belt with infinitely adjustable speed

alternatively with

- height adjustable **pressure board DB**, - as forming station **SCHR-DB**, for the production of *folded, folded long rolled or long rolled dough pieces*
- or height adjustable **top belt RR** - speed infinitely adjustable, direction of rotation reversible,- as forming station **SCHR-RR** for the *additional production of flattened dough pieces*
- timing roller for row correction of the long rolled dough pieces
- working widths: 610, 800 and 1000 mm

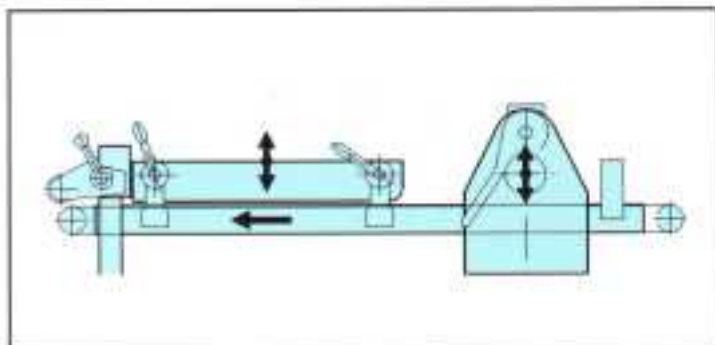

Forming station SCHR-DB

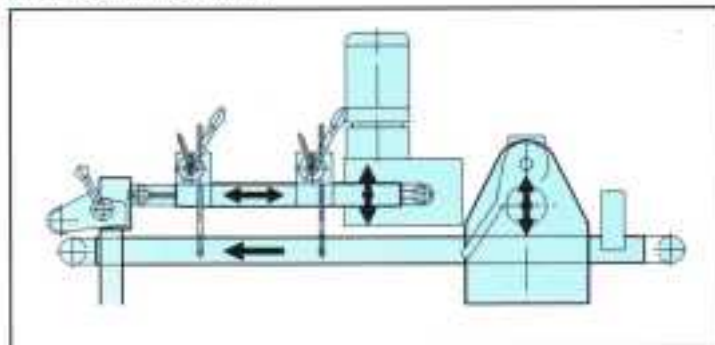

Forming station SCHR-RR

Convoluting unit WDK-...

Consisting of:

- double roller sheeting head with adjustable clearance and duster for the upper roller
- mountable folding claws or drag belts
- convoluting belt with infinitely adjustable speed and reversible direction of rotation - **WDK**
- bottom belt with infinitely adjustable speed

alternatively with

- height adjustable **pressure board DB**, - as forming station **WDK-DB**, for the production of *folded, folded long rolled, long rolled and convoluted dough pieces*
- or height adjustable **top belt RR**, speed infinitely adjustable, direction of rotation reversible,- as forming station **WDK-RR** for the *additional production of flattened dough pieces*
- timing roller for row correction of the long rolled dough pieces
- working widths: 610, 800 and 1000 mm



Forming station WDK-DB



Forming station WDK-RR



Waterbath seeder MO(WB)

- complete wetting in the waterbath with controllable water level
- dense and uniform application of the seeding material from below by means of speed controlled brush - installed within the strewing box
- automatic refilling of the strewing box
- especially suitable for stamped rolls with raised surface (e.g. Kaiser rolls)
- working widths: 610 und 800 mm

available on request with

- wetting from both sides and additional seeding from above
- automatic discharge of the surplus seeding material
- automatic transport of the surplus seeding material back to the strewing boxes

Minimum effort for maintenance and cleaning due to

- full isolation of the drive parts from the working area
- net belts which can be changed over easily and quickly to plastic belts



Strewing seeder MO(ST)

- uniform wetting of the dough pieces by means of wetting rollers with top mounted adjustable drop nozzles
- application of various seeding materials is possible
- undisturbed continuous operation by means of permanent cleaning of the wetting roller via vacuum suction system with cyclone separator
- the whole seeder unit can be removed easily and quickly from the line for cleaning and replaced by an intermediate belt
- seeding from above by means of strewing boxes with quantity adjustment
- several, independent strewing boxes can be fitted one behind the other
- working widths: 600, 800 and 1000 mm

